

Telephone:
Fax:

Name: **Manufacturer:** Peugeot
Address: **Model:**
Tel - Private: **Year:** 2000
Tel - Business: **Registration:**
Tel - Mobile: **Mileage:**
Job number:
Date

K143	AC compressor clutch relay
S341	AC refrigerant triple pressure switch
31	Battery -
30	Battery +
B132	Camshaft position (CMP) sensor
R57	Crankcase breather heater
B54	Crankshaft position (CKP) sensor
X1	Data link connector (DLC)
EP3	Earth point location 3
EP6	Earth point location 6
A35	Engine control module (ECM)
A95	Engine coolant blower motor control module
B24	Engine coolant temperature (ECT) sensor
H63	Engine malfunction indicator lamp (MIL)
Y104	Evaporative emission (EVAP) canister purge valve
M12	Fuel pump
F	Fuse
X28-II	Fuse box/relay plate, engine bay
X28-I	Fuse box/relay plate, fascia
B72	Heated oxygen sensor (HO2S)
Y99	Idle air control (IAC) valve
A52	Ignition amplifier
T1	Ignition coil
15	Ignition switch - ignition ON
A162	Immobilizer control module
S39	Inertia fuel shut-off (IFS) switch
Y3	Injector
A5	Instrument panel
B25	Intake air temperature (IAT) sensor
B69	Knock sensor (KS)
B83	Manifold absolute pressure (MAP) sensor
A11	Multifunction control module
S231	Power steering pressure (PSP) switch
A171	Relay module
P7	Tachometer
R10	Throttle body heater

B147	Throttle position (TP) sensor
B33	Vehicle speed sensor (VSS)
P9	Vehicle speedometer

bl = blue	br = brown	el = cream	ge = yellow
gn = green	gr = grey	nf = neutral	og = orange
rs = pink	rt = red	sw = black	vi = violet
ws = white	hbl = light blue	hgn = light green	rbr = maroon
x = braided cable	y = high tension	z = non-cable connection	

NOTE: In certain diagrams (Citroen, Peugeot & Renault), colour codes are replaced by numbers which are used to identify a particular cable and not the colour. In this instance, the cables will be numbered at each end close to the harness connector.

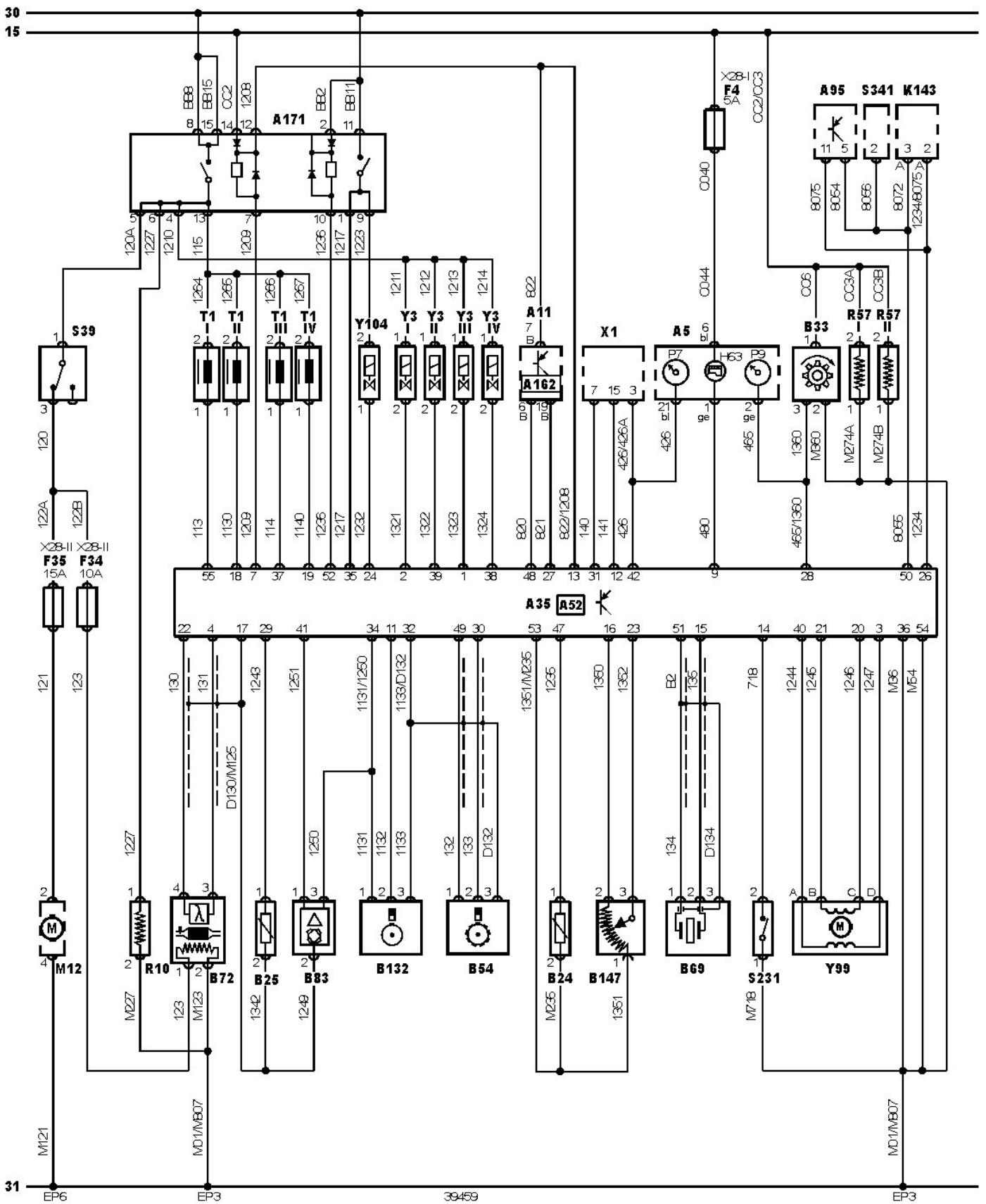

39459