

Telephone:  
 Fax:  
 VAT Registration No.:

A16	ABS control module
S341	AC refrigerant triple pressure switch
B138	Accelerator pedal position (APP) sensor
B121	Barometric pressure (BARO) sensor
31	Battery -
30	Battery +
S13	Brake pedal position (BPP) switch
B132	Camshaft position (CMP) sensor
S258	Clutch pedal position (CPP) switch
CAN-H	Controller area network (data bus) high
CAN-L	Controller area network (data bus) low
B54	Crankshaft position (CKP) sensor
X1	Data link connector (DLC)
A207	Electronic stability programme (ESP) control module
A35	Engine control module (ECM)
M6	Engine coolant blower motor
K12	Engine coolant blower motor relay
R46	Engine coolant blower motor resistor
K242	Engine coolant heater relay
B24	Engine coolant temperature (ECT) sensor
H63	Engine malfunction indicator lamp (MIL)
B127	Exhaust gas pressure sensor
Y28	Exhaust gas recirculation (EGR) solenoid
B131	Exhaust gas temperature sensor
A242	Fuel additive control module
Y199	Fuel additive injector
M153	Fuel additive pump
S424	Fuel filler cap position switch
R64	Fuel filter heater
S266	Fuel filter warning lamp switch
Y63	Fuel pressure regulator control solenoid
M12	Fuel pump
B26	Fuel system pressure sensor
B31	Fuel temperature sensor
B82	Fuel/water separator sensor
F	Fuse

**Manufacturer:** Peugeot  
**Engine code:** DW12ATED (4HX)  
**Tuned for:**

**Model:** 406 2,2D HDi  
**Output:** 98 (133) 4000  
**Year:** 2001-04

© Autodata Limited 2007  
 04/02/2012  
 V6.410- ***/Autodata***

X28-II	Fuse box/relay plate, engine bay 1
X28-III	Fuse box/relay plate, engine bay 2
X28-V	Fuse box/relay plate, engine bay 3
X28-I	Fuse box/relay plate, fascia 1
X28-IV	Fuse box/relay plate, fascia 2
K93	Glow plug timer relay
H25	Glow plug warning lamp
R5	Glow plugs
15	Ignition switch - ignition ON
Y3	Injector
A5	Instrument panel
A75	Instrumentation control module
B25	Intake air temperature (IAT) sensor
Y84	Intake air valve control valve
Y102	Intake manifold air control solenoid
B83	Manifold absolute pressure (MAP) sensor
B30	Mass air flow (MAF) sensor
A11	Multifunction control module
Y160	Piston cut-off solenoid
H111	Stop engine warning lamp
P7	Tachometer
15	Tailgate, RH
A57	Transmission control module (TCM)
Y68	Turbocharger (TC) wastegate regulating valve
VAN	Vehicle area network (data bus)
P9	Vehicle speedometer

bl = blue	br = brown	el = cream	ge = yellow
gn = green	gr = grey	nf = neutral	og = orange
rs = pink	rt = red	sw = black	vi = violet
ws = white	hbl = light blue	hgn = light green	rbr = maroon
x = braided cable	y = high tension	z = non-cable connection	

**NOTE:** In certain diagrams (Citroen, Peugeot & Renault), colour codes are replaced by numbers which are used to identify a particular cable and not the colour. In this instance, the cables will be numbered at each end close to the harness connector.

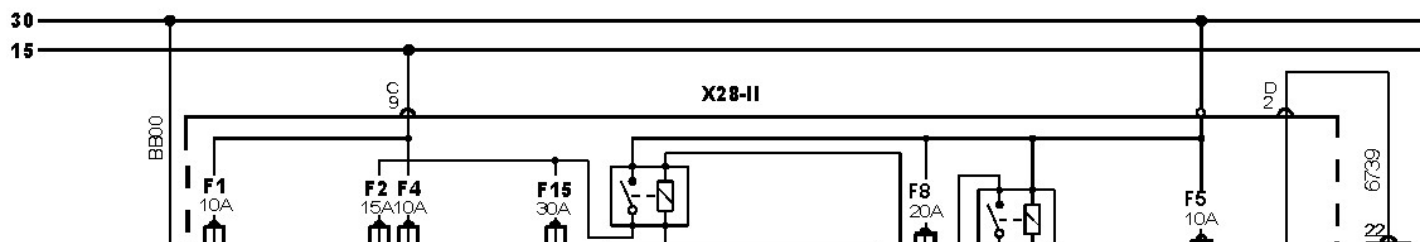

Manufacturer: Peugeot  
 Engine code: DW12ATED (4HX)  
 Tuned for:

Model: 406 2,2D HDi  
 Output: 98 (133) 4000  
 Year: 2001-04

© Autodata Limited 2007  
 04/02/2012  
 V6.410- **/Autodata**

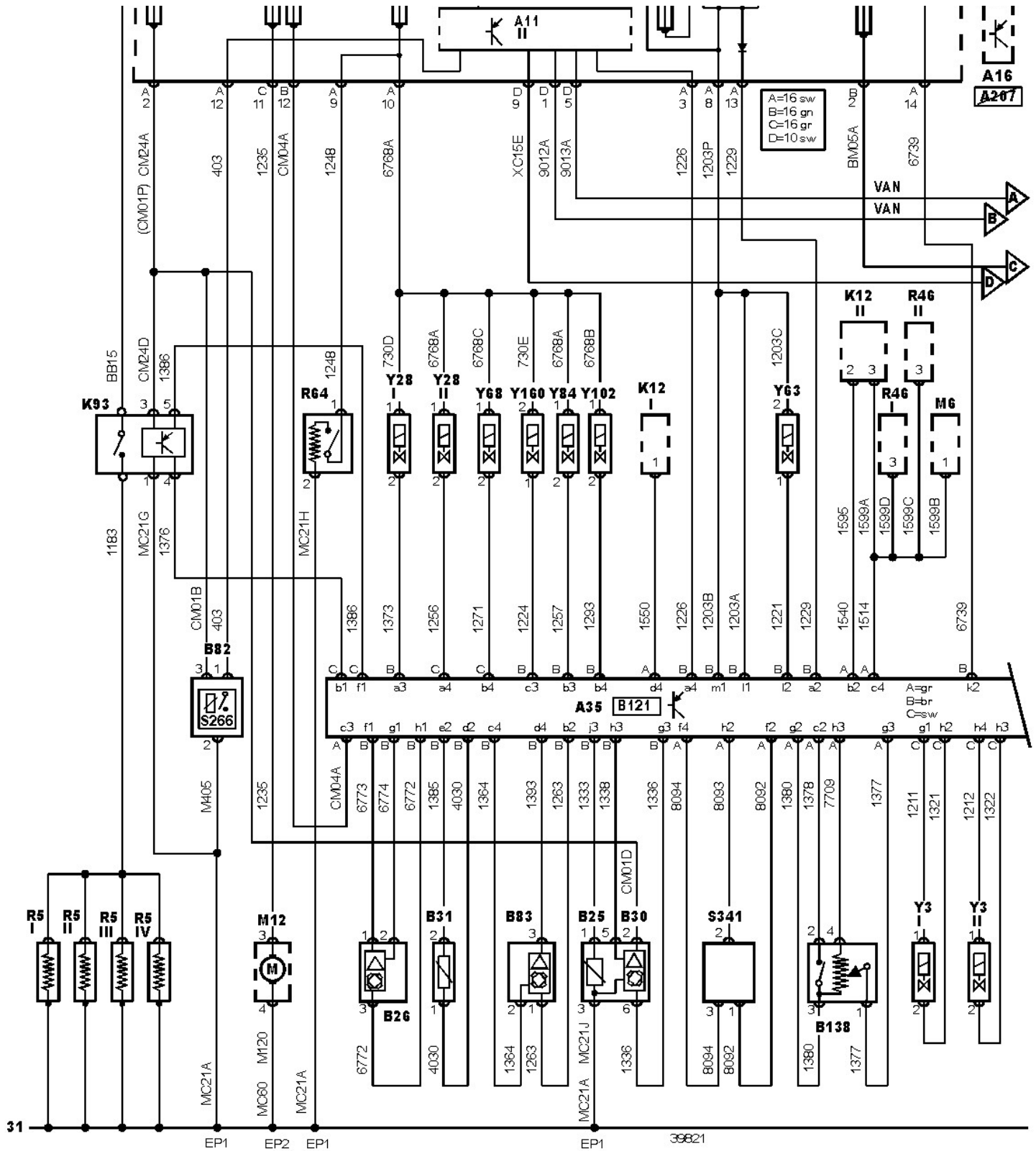

Manufacturer: Peugeot  
 Engine code: DW12ATED (4HX)  
 Tuned for:

Model: 406 2,2D HDi  
 Output: 98 (133) 4000  
 Year: 2001-04

© Autodata Limited 2007  
 04/02/2012  
 V6.410- **/Autodata**

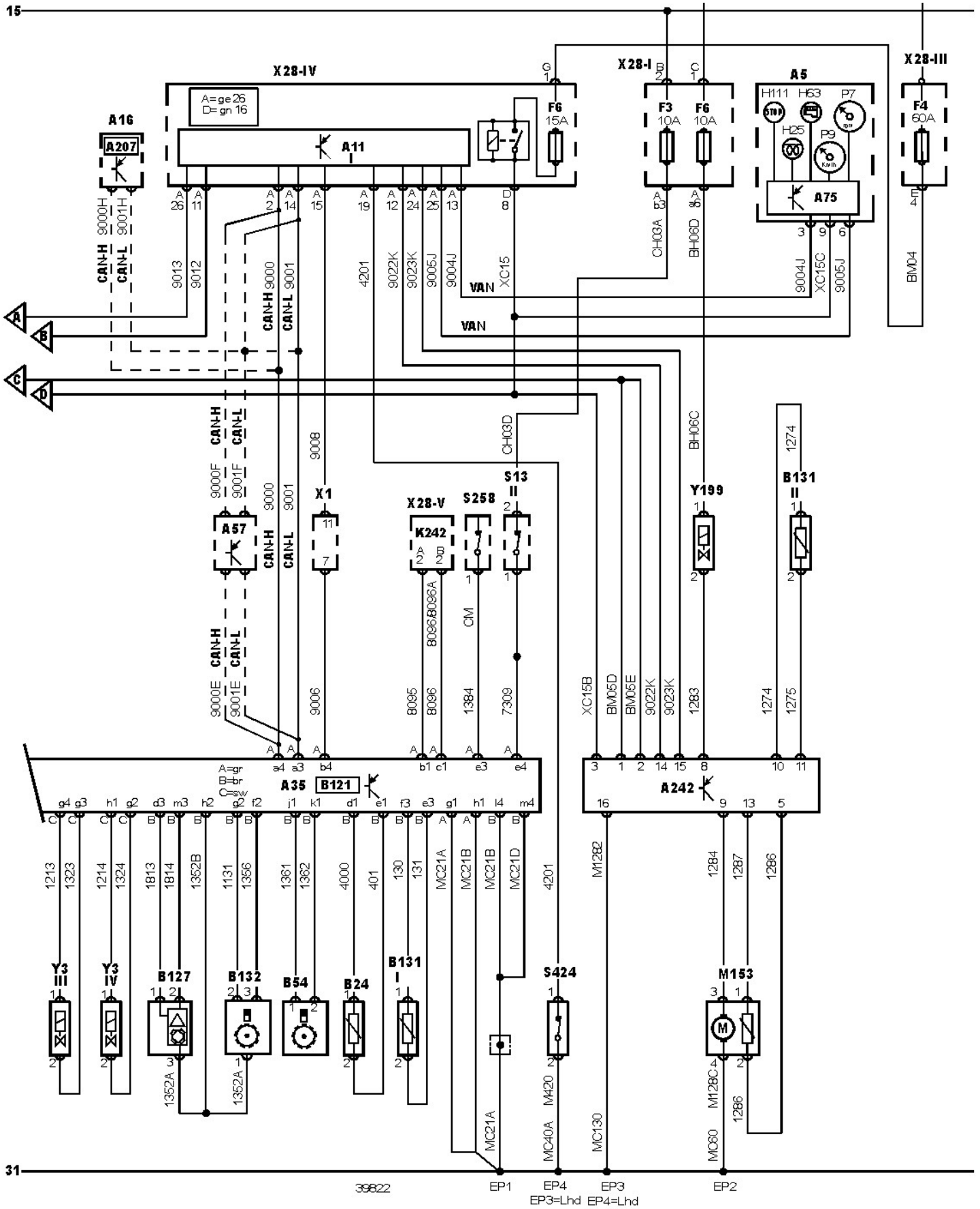

Manufacturer: Peugeot  
 Engine code: DW12ATED (4HX)  
 Tuned for:

Model: 406 2,2D HDi  
 Output: 98 (133) 4000  
 Year: 2001-04

© Autodata Limited 2007  
 04/02/2012  
 V6.410- **/Autodata**

**Manufacturer:** Peugeot  
**Engine code:** DW12ATED (4HX)  
**Tuned for:**

**Model:** 406 2,2D HDi  
**Output:** 98 (133) 4000  
**Year:** 2001-04

© Autodata Limited 2007  
04/02/2012  
V6.410- ***/Autodata***